

LE15S

Thermal Monocular



HIKMICRO LYNX S LE15S thermal monocular is equipped with a 256×192 infrared detector and an 800×600 OLED display. It supports functions of observation, distance measurement, hotspot, and so on. The high-sensitivity built-in thermal detector provides you with a clear view even in total darkness. The monocular is mainly applied to scenarios such as hunting, hiking, searching and rescuing, etc.

Key Feature

- 256×192 resolution, $12 \mu\text{m}$, high sensitivity detector
- Adaptive AGC, DDE, 3D DNR
- NETD less than 35 mK (@ 25°C , $F\# = 1.0$)
- 800×600 resolution 0.32-inch OLED display
- Built-in rechargeable lithium battery
- Up to 8 hours continuous running
- Support hotspot

Specification

Thermal Module	
Image Sensor	VOx Uncooled Focal Plane Arrays
Max. Resolution	256 × 192
Frame Rate	50 Hz
Pixel Interval	12 μm
Response Waveband	8 μm to 14 μm
NETD	Less than 35 mK (@25°C), F# = 1.0
Lens (Focal Length)	15 mm, F1.0
Detection Range	750 m
Focus Mode	Focus Free
Min. Focusing Distance	10 m
Magnification	2.2× to 17.6× (8×)
Field of View(H × V), Degrees / m @100 m	11.7° × 8.8° / 20.5 m × 15.4 m
Image Display	
Display	800 × 600, 0.32-inch, OLED
Palettes	Black Hot, White Hot, Red Hot, Fusion
FFC (Flat Field Correction) Mode	Auto, Manual, External Correction
Exit Pupil	20 mm
Eye Relief	6 mm
Diopter (Range)	-5D to +4D
Brightness Adjustment	Yes
Tone Adjustment	Cold, Warm
Contrast Adjustment	Yes
System	
Record Video	Yes
Capture Snapshot	Yes
Audio Recording	Yes
Standby Mode	Yes
Storage	Built-in memory module (8 GB)
PIP	Yes
Hotspot	Yes
Hot Track	Yes
Distance Measurement	Yes
Power Supply	
Battery Type	Rechargeable Lithium Battery
Battery Operating Time	8 hours continuous running with hotspot function off (@25°C) 6 hours continuous running with hotspot function on (@25°C)
Type-C Power Supply	DC 5 V/2 A Supports External Power Supply

General	
Protection Level	IP67
Dimension	158.3 mm × 61 mm × 57 mm (6.23" × 2.40" × 2.24")
Working Temperature	- 20°C to 55°C (-4°F to 131°F)
Weight	280 g (0.62 lbs)

• Available Model

HM-TS02-15S1G/W-LE15S

• Dimension

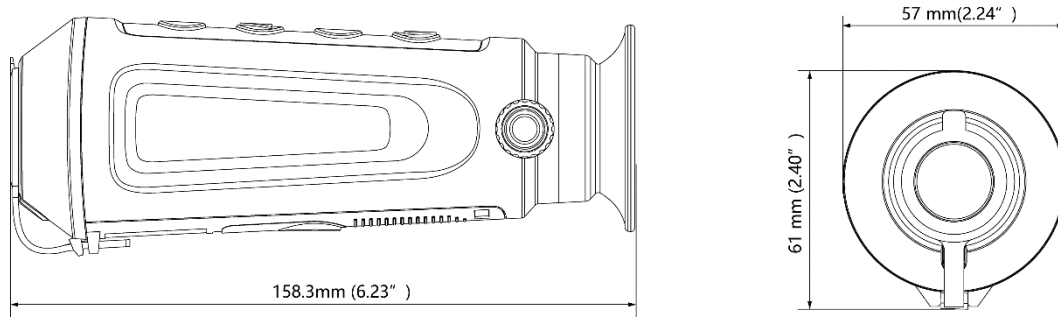

• Accessories

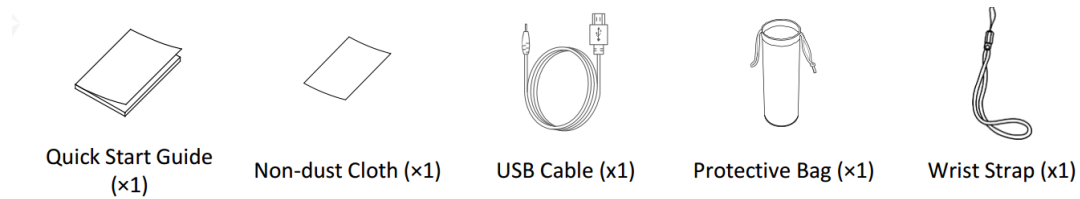

COMPLIANCE NOTICE: The thermal series products might be subject to export controls in various countries or regions, including without limitation, the United States, European Union, United Kingdom and/or other member countries of the Wassenaar Arrangement. Please consult your professional legal or compliance expert or local government authorities for any necessary export license requirements if you intend to transfer, export, re-export the thermal series products between different countries.



HIKMICRO SIGHT



Hikmicro Hunting.Global HIKMICRO Outdoor www.hikmicrotech.com hikmicro hunting.global HIKMICRO info@hikmicrotech.com

room 313, unit B, building 2, 399 danfeng road, xixing subdistrict, binjiang district, hangzhou, zhejiang
@hangzhou microimage software co., Ltd .2024 | data subject to change without notice!